

FOLDING DOOR BEAD & RAIL FORMULA

The true Rail & Bead length is critical to success of assembling a folding door. The Rail & Bead length generated from estimating software QuoCut Professional, Cre8 (V6) or of the manual listing procedure is based on nominal sizes. The unavoidable variance in metal tolerance and Powder coat or Anodised finishes is not considered. **If the nominal Rail & Bead sizes were used the door would not be able to close.**

To determine the true Rail & Bead lengths the following procedure should be followed once the materials to be used are in hand to avoid fabrication and functional issues.

STEP ONE

- Lay out the stiles across your assembly table in the same sequence as assembled. Position together to eliminate any spaces.
- Accurately measure the Stile Total (ST) to the nearest 0.5mm

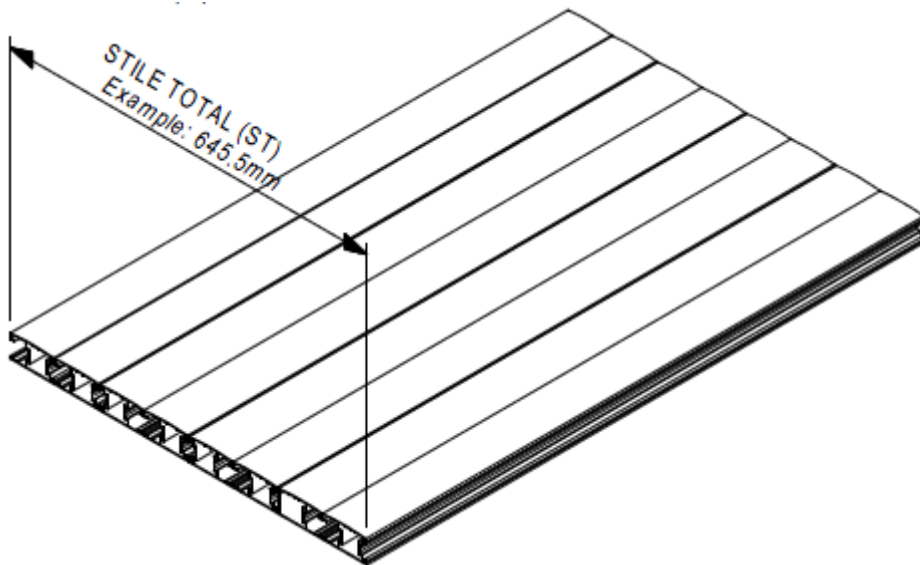

STEP TWO

- Determine the panel width (PW) value from Cutting Formula & BOM indicated in the relevant Technical Manual

STEP THREE

- Calculate the True Rail & Bead Length –
 - $PW - (ST \div \text{Number of Panels})$

Important! Ensure rails are cut accurately.